

050-0300
Single Rotor Latch



DESIGNED FOR:

- Most storage, compartment and access doors
- Windows
- Any application where finger or remote release is desired

Global Locations:

TriMark Corporation
500 Bailey Avenue
P.O. Box 350
New Hampton, Iowa 50659
United States
Tel: 641-394-3188
Fax: 641-394-2392
1-800-447-0343
www.trimarkcorp.com

TriMark Europe
Cedar Court
Walker road
Bardon Hill
Coalville LE67 1TU
United Kingdom
Tel: +44(0)1530 512460
Fax: +44(0)1530 512461
www.trimarkeu.com

TriMark (Xuzhou)
Building A5 Jingwu Road
Xuzhou Economic
Development Zone
Xuzhou, Jiangsu
221004 PR China
Tel: +86 516 8773 0018
Fax: +86 516 8773 0058
www.trimarkcn.com



TriMark. Interactive. Product. Selector



TriMark



TriMark Corporation

AVAILABLE:

- Latch is non-handed, but trip lever handing is available
- With (2) 1/4-20 UNC or M6 x 1.0 threaded axles or .265" (6.7mm) diameter "thru" axles

MATERIAL:

- Strike, rotor and rotor catch: heat treated, smooth edge stamped steel
- Case halves: zinc plated, mild steel components

INSTALLATION:

- (2) 1/4-20 UNC grade 5-type or M6 x 1.0 class 8.8 or better fasteners are required fasteners (not included)
- Tighten to fastener manufacturers' recommended torque value, however, do not exceed 120 in-lbs. (13.3 N-m)

INTERNAL LUBRICATION:

- Oven-cured dry lubricant is applied to catch and rotor

LATCH & STRIKER INSTALLATION:

- Install striker bolt in door frame
- Close door carefully and check for interference between head of striker bolt and latch components
- Add or remove shims under striker bolt washer as required (outside diameter of shim should be larger than outside diameter of striker bolt washer)
- Adjust striker bolt vertically so door is not guided upward or downward while being closed
- CHECK TO DETERMINE THAT BOTH SECONDARY AND PRIMARY LATCHING POSITIONS ARE USABLE
- Door should be latched but not "closed" in secondary position and latched to anticipated "closed" position with respect to adjacent surfaces in primary position
- If both primary and secondary positions are not evident, readjust striker bolt
- After installation, check door alignment and door seal pressures

CAUTION: Latch does not meet FMVSS 206 (ECE R11) load requirements.

Individual part dimensions are for reference only. Refer to individual part drawings for complete dimensions, specifications, and installation procedures. Engineering assistance and application drawings are available.

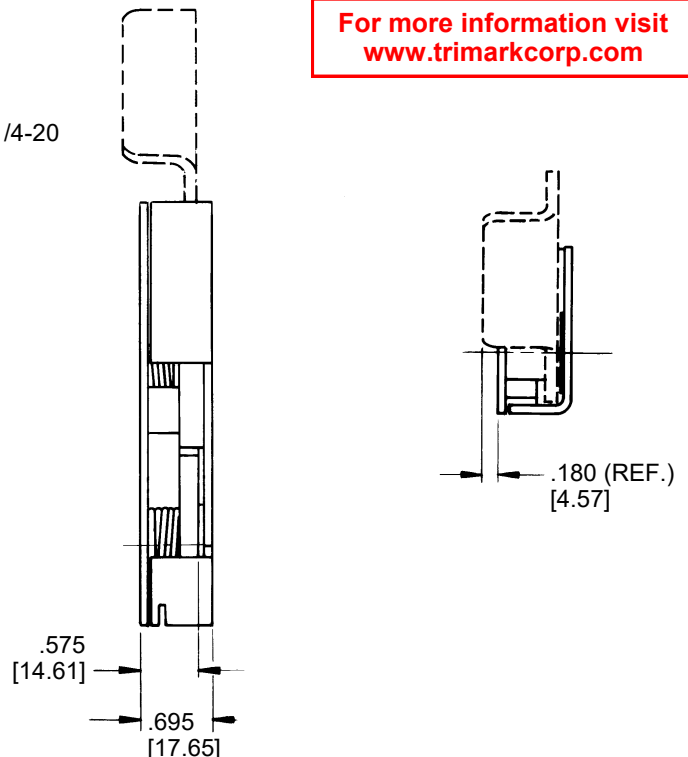
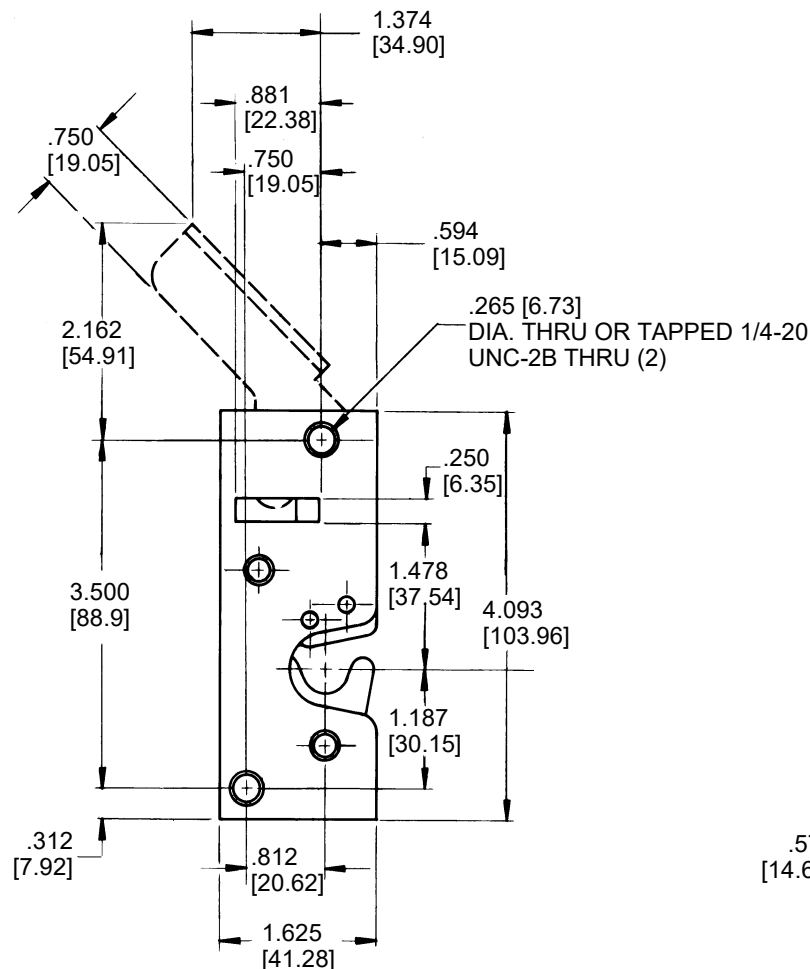

For more information visit www.trimarkcorp.com